

ScanVein Rugged

#biometrics

#palmwein

#accesscontrol

PALM VEIN SCANNER FOR SAFETY AREAS

The **ScanVein Rugged** palm vein scanner was developed as high security biometrical access system designed for computing centers, office buildings, research labs, power plants or airports and is based on Fujitsu PalmSecure technology.

Even at maritime areas with direct sunlight and constant impact of salt-water, the **ScanVein Rugged** palm vein scanner with its V4A stainless steel casing is available at any time. Using the highly unique vascular pattern of ones palm, the access system provides high security and comfort for its users.

The **ScanVein Rugged** palm vein scanner features a broad collection of interfaces, which allows an easy integration into existing security infrastructure.

Moreover, the integrated soft- and hardware backup systems ensure the highest possible system availability.

This **ScanVein Rugged** is the world's first palm vein recognition sensor for outdoor use and even meets military EMV and EMP requirements. The casing is solid "V4A Stainless-Steel" and therefore sturdy, allweather-proof and features an internal thermal management which has been tested in temperatures from -25° to +85°C.





Your benefits

- Can be used in almost any environment
- High Usability
- Stronger security than Iris scan technology
- FAR < 0.00008% (false acceptance rate)
- FRR < 0.01% (false rejection rate)
- Easy integration into existing systems
- Integrated Fujitsu PalmSecure Sensor
- Certified according to CE, BSI (components)
- EMC-protected, ex-protected (optional)

Technical features

- Interfaces: Wiegand\ClkData In, Wiegand\ClkData, Out, CAN, RS-232, RS-485, Relay, GPIO
- Communication I/F: Ethernet
- Integrated RFID transceiver, (Mifare Desfire EV1 or Legic Advant; option)
- Housing: IP68 Standard
- Max ambient light intensity 100.000 Lux
- Can be installed in direct sun light
- Identification or verification mode
- Temperature range from -25° to +85°C

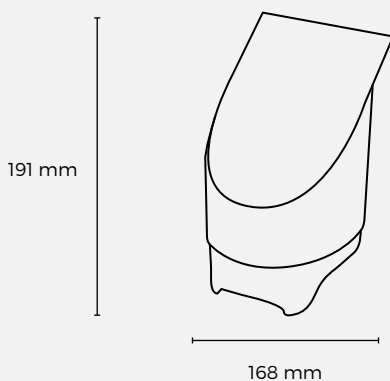

External dimensions:

191 x 168 x 244 mm (HxWxD)

Mount dimensions:

191 x 168 x 244 mm (HxWxD)

Installation height (higher edge):

115 cm

Body housing:

V4A stainless-steel,
IP68 standard

Power supply:

Power over Ethernet (IEEE802.3af)

Standards:

CE compliant
BSI (components)